

ALU LSW BLC – both side absorbent

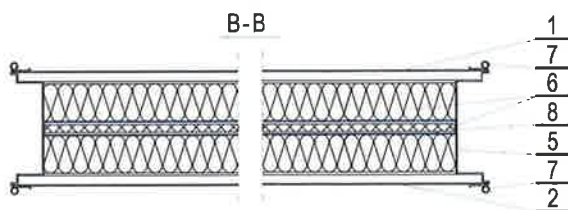

Systematic Solutions

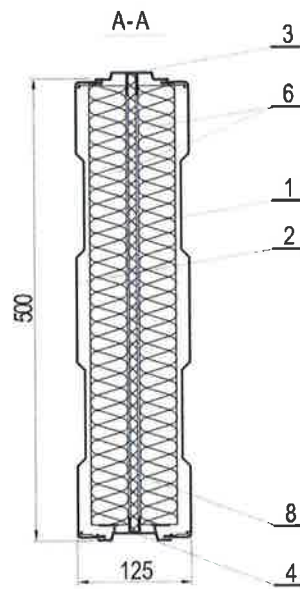
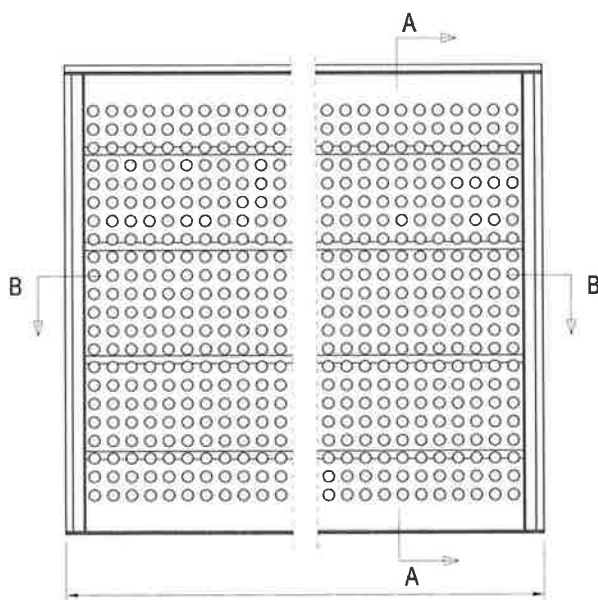
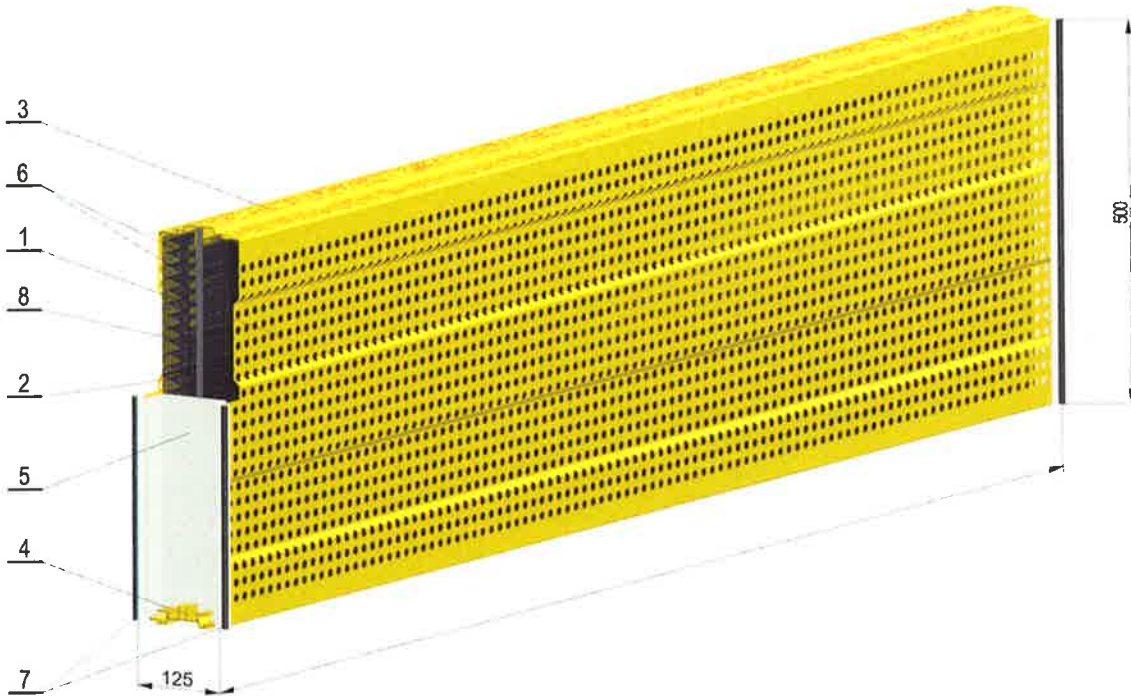

- 1 - Vorderblech 1,25 mm (gelocht)
- 2 - Rückblech 1,25 mm (gelocht)
- 3 - Obergurt (stranggepresst)
- 4 - Untergurt (stranggepresst)
- 5 - Seitenprofil (stranggepresst)
- 6 - Steinwolle 40 mm - 120 kg/m
- 7 - Rundschnurdichtung
- 8 - Holzzement - platte



notified body NB 0800		09	DIN EN 14388:2005		
Alumero Systematic Solutions GmbH Sonnenweg 1-2, 5164 Seeham, ÖSTERREICH		 Systematic Solutions			
Produktion Alumero Metal Components Sp.z.o.o Kluczborska 29, 41-508 Chorzów, POLEN					
ALU LSW BLC – both-side absorbent		Noise protection elements for reduction of noise along traffic routes			
Construction of the product		Type Standard, sound-reflecting, Strip thickness 1,25 mm			
Requirements		Accomplishment			
Noise absorption DL_{α}		12 dB, Group A4			
Sound damping DL_R		27 dB, Group B3			
Force stability		2 m	3 m	4 m	5 m
Tare weight of a noise protection element:					
- wet		1,112 kN	1,668 kN	2,224 kN	2,780 kN
- reduced wet-weight		0,318 kN	0,480 kN	0,640 kN	0,805 kN
- dry		0,286 kN	0,429 kN	0,576 kN	0,720 kN
Highest vertical load, the element must bear against (because of stocked elements)		acc. static evaluation Dipl.-Ing. G. Tomasev			
Highest normal load (90°), the element must bear against (wind force and static load)		acc. test report S2.2/09-297-3 für 1,96m and test report TM-1/29/07 für 4,96m			
Highest normal load (90°), the element must bear against (dynamic loads due to snow removal)		acc. test report S2.2/09-297-4			
Risk of falling structures		category 3			
Riprap resistance		acc. DIN EN 1794-1:03, enclosure C			

Description of noise protection wall

- Upper- and under chord is out of extruded Aluminium profiles
- Side-sheets with 2 aluminium pleats, one-side punched
Hole diameter 6 mm or 12 mm, hole rate: 25 %
- Side-cap is out of extruded Aluminium profiles
- Inside 40 mm rock wool, density 120 kg/m³
- Single parts are mounted with rivets

 Dipl.-Bet.-Oec (Bl)
Manfred Rosenstatter
 CEO



 Ing.
Peter Pichkostner
 Qualitätsmanagement

Document composition

Criteria	Executive unit	Documents
Noise absorption DL α	LGA QualiTest GmbH	Test report QEMATAS 8461176-AT1a
Sound damping n DLR	LGA QualiTest GmbH + MFPA Leipzig	
Tare weight	MFPA Leipzig	Test report S2.2/09-297-2
Highest vertical load,...	Dipl.-Ing. G. Tomasev, Salzburg	Static evaluation
Highest normal load (90°), ...(wind force)	MFPA Leipzig	Test report S2.2/09-297-3 for 1,96m length
	Research institute for streets and bridges, Warsaw	Test report TM-1/29/07 for 4,96m length
Highest normal load (90°), ...(dynamic load due to snow removal)	MFPA Leipzig	Test Report S2.2/09-297-4
Risk of falling wall sections	MFPA Leipzig	Test report S2.2/09-297-1

The tests were done acc to the following norms:

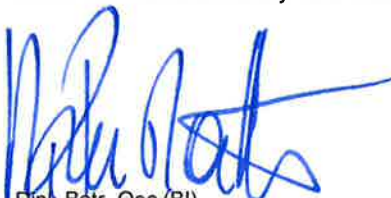
- DIN EN 14388; issue 2005-10; noise protection facilities at roads - regulation
- 01N EN 1793-1; issue 1997-11; noise protection facilities at roads – test procedure to determinate the acoustic properties - Part 1: Produce specific description of sound absorption
- DIN EN 1793-2; issue 1997-11; noise protection facilities at roads – test procedure to determinate the acoustic properties - Part 2: Produce specific description of airborne sound absorption
- DIN EN 1794-1; issued 2003-07; noise protection facilities at roads – Not acoustic properties
- Part 1: Mechanical properties and requirements regarding stability
- DIN EN 1794-2; issue 2003-07; noise protection facilities at roads - Not acoustic properties
- Part 2: General safety and environmental requirements

 Dipl.-Betr.-Oec (BI)
Manfred Rosenstatter
 CEO

 Ing.
Peter Pichkostner
 quality management

ALUMERO

Systematic Solutions

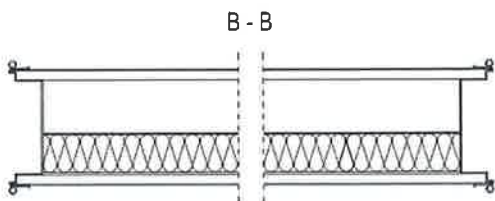
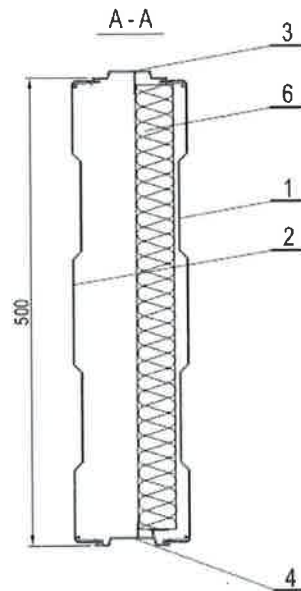
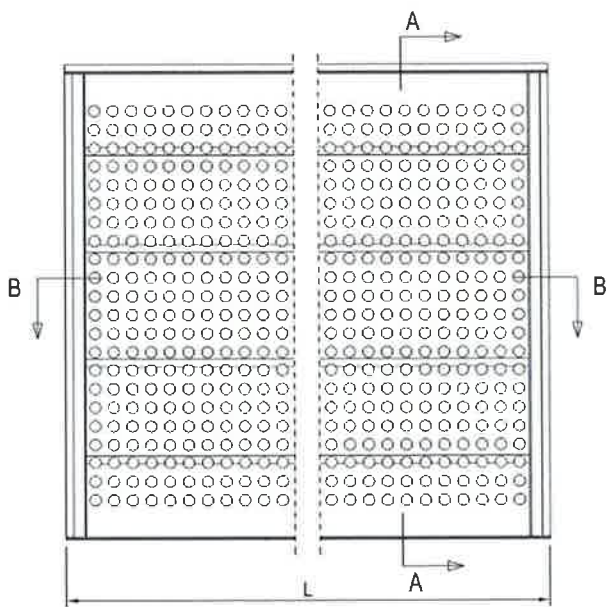
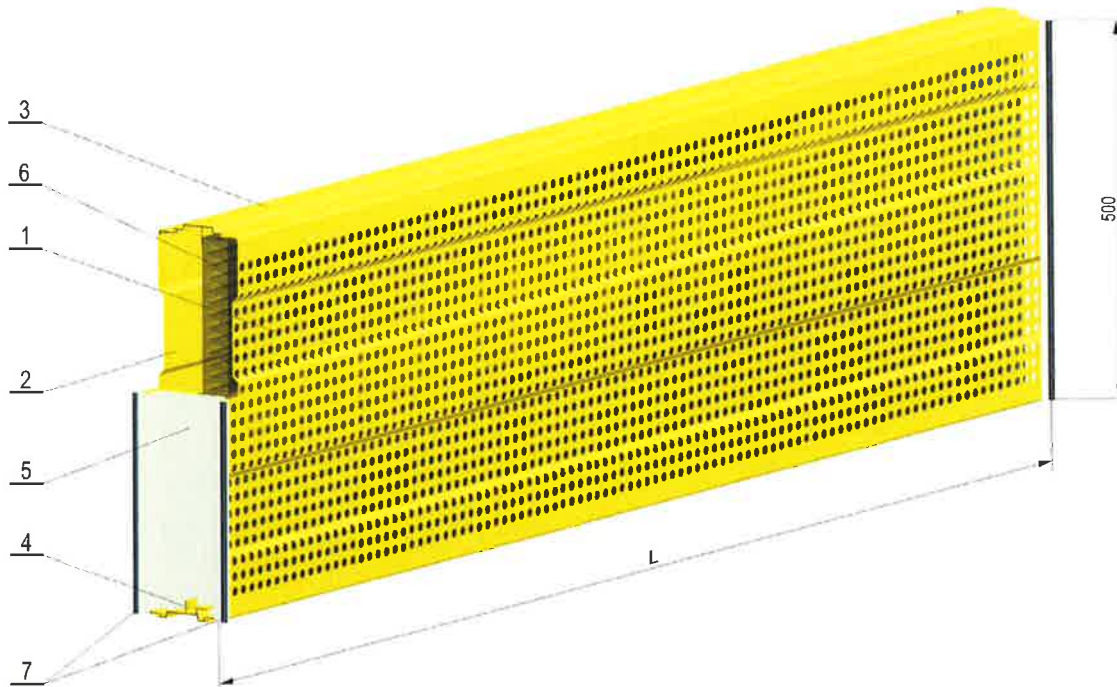

- 1 - Vorderblech (gelocht)
 - 2 - Rückblech (ungelocht)
 - 3 - Obergurt (stranggepresst)
 - 4 - Untergurt (stranggepresst)
 - 5 - Seitenprofil (stranggepresst)
 - 6 - Steinwolle
 - 7 - Rundschnurdichtung
- L = 4960, 3960, 2960, 2460, 1960 mm



notified body NB 0800		09	DIN EN 14388:2005		
Alumero Systematic Solutions GmbH Sonnenweg 1-2, 5164 Seeham, ÖSTERREICH		 Systematic Solutions			
Produktion Alumero Metal Components Sp.z.o.o Kluczborska 29, 41-508 Chorzów, POLEN					
ALU LSW ELC – one-side absorbent		Noise protection elements for reduction of noise along traffic routes			
Construction of the product		Type Standard, sound-reflecting, Strip thickness 1,25 mm			
Requirements		Accomplishment			
Noise absorption DL_{α}		11 dB, Group A4			
Sound damping DL_R		25 dB, Group B3			
Force stability		2 m	3 m	4 m	5 m
Tare weight of a noise protection element:					
- wet		1,112 kN	1,668 kN	2,224 kN	2,780 kN
- reduced wet-weight		0,166 kN	0,243 kN	0,312 kN	0,380 kN
- dry		0,148 kN	0,219 kN	0,288 kN	0,355 kN
Highest vertical load, the element must bear against (because of stocked elements)		acc. static evaluation Dipl.-Ing. G. Tomasev			
Highest normal load (90°), the element must bear against (wind force and static load)		acc. test report S2.2/09-297-3 für 1,96m and test report TM-1/29/07 für 4,96m			
Highest normal load (90°), the element must bear against (dynamic loads due to snow removal)		acc. test report S2.2/09-297-4			
Risk of falling structures		Category 3			
Riprap resistance		acc. DIN EN 1794-1:03, enclosure C			

Description of noise protection wall

- Upper- and under chord is out of extruded Aluminium profiles
- Side-sheets with 2 aluminium pleats, one-side punched
Hole diameter 6 mm or 12 mm, hole rate: 25 %
- Side-cap is out of extruded Aluminium profiles
- Inside 40 mm rock wool, density 120 kg/m³
- Single parts are mounted with rivets

 Dipl.-Betriebs-Öec (B)
Manfred Rosenstatter
 CEO



 Ing.
Peter Pichlkostner
 quality management

Document composition

Criteria	Executive unit	Documents
Noise absorption DL α	LGA QualiTest GmbH	Test report QEMATAS 8461176-AT1a
Sound damping n DLR	LGA QualiTest GmbH + MFPA Leipzig	
Tare weight	MFPA Leipzig	Test report S2.2/09-297-2
Highest vertical load, ...	Dipl.-Ing. G. Tomasev, Salzburg	Static evaluation
Highest normal load (90°), ... (wind force)	MFPA Leipzig	Test report S2.2/09-297-3 for 1,96m length
	Research institute for streets and bridges, Warsaw	Test report TM-1/29/07 for 4,96m length
Highest normal load (90°), ... (dynamic load due to snow removal)	MFPA Leipzig	Test Report S2.2/09-297-4
Risk of falling wall sections	MFPA Leipzig	Test report S2.2/09-297-1

The tests were done acc to the following norms:

- DIN EN 14388; issue 2005-10; noise protection facilities at roads - regulation
- 01N EN 1793-1; issue 1997-11; noise protection facilities at roads – test procedure to determinate the acoustic properties - Part 1: Produce specific description of sound absorption
- DIN EN 1793-2; issue 1997-11; noise protection facilities at roads – test procedure to determinate the acoustic properties - Part 2: Produce specific description of airborne sound absorption
- DIN EN 1794-1; issue 2003-07; noise protection facilities at roads – Not acoustic properties - Part 1: Mechanical properties and requirements regarding stability
- DIN EN 1794-2; issue 2003-07; noise protection facilities at roads - Not acoustic properties - Part 2: General safety and environmental requirements



Dipl. Betr.-Oec (BI)
Manfred Rosenstatter
CEO

Ing.
Peter Pichlkostner
quality management

ALU LSW RLC – sound reflecting

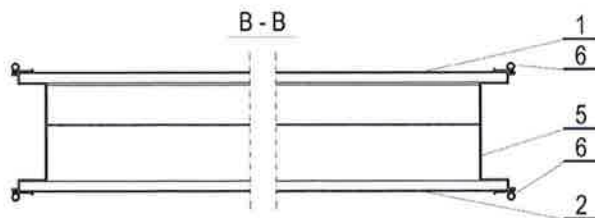
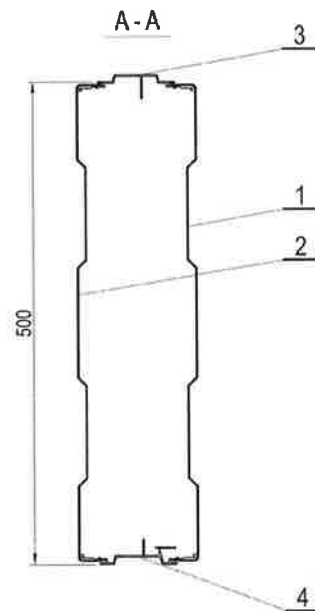
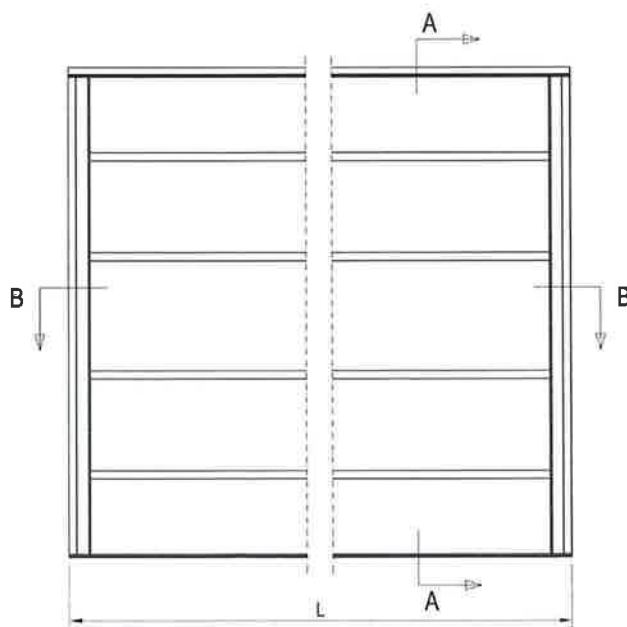
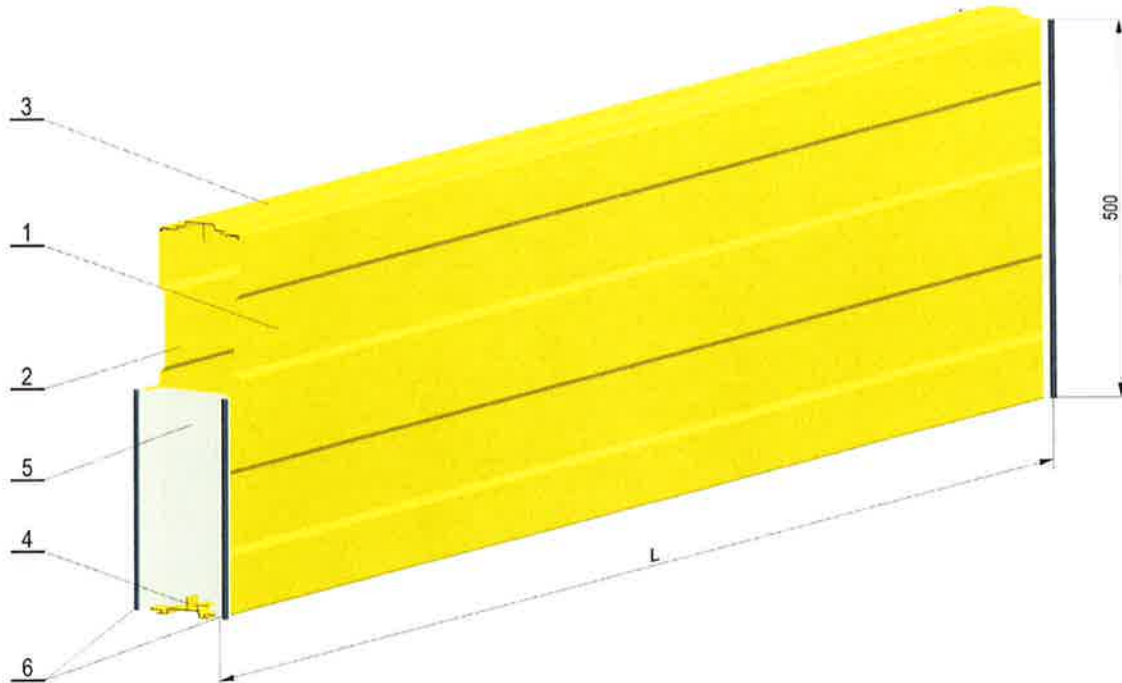

Systematic Solutions



- 1 - Vorderblech (ungelocht)
 - 2 - Rückblech (ungelocht)
 - 3 - Obergurt (stranggepresst)
 - 4 - Untergurt (stranggepresst)
 - 5 - Seitenprofil (stranggepresst)
 - 6 - Rundschnurdichtung
- L = 4960, 3960, 2960, 2460, 1960 mm



notified body NB 0800		09	DIN EN 14388:2005		
Alumero Systematic Solutions GmbH Sonnenweg 1-2, 5164 Seeham, ÖSTERREICH		 Systematic Solutions			
Produktion Alumero Metal Components Sp.z.o.o Kluczborska 29, 41-508 Chorzów, POLEN					
ALU LSW RLC – sound-reflecting		Noise protection elements for reduction of noise along traffic routes			
Construction of the product		Type Standard, sound-reflecting, Strip thickness 1,25 mm			
Requirements		Accomplishment			
Sound damping DL _R		26 dB, Group B3			
Force stability		2 m	3 m	4 m	5 m
Tare weight of a noise protection element:					
- wet		1,112 kN	1,668 kN	2,224 kN	2,780 kN
- reduced wet-weight		0,106 kN	0,159 kN	0,212 kN	0,265 kN
- dry		0,078 kN	0,135 kN	0,192 kN	0,265 kN
Highest vertical load, the element must bear against (because of stocked elements)		Acc. static evaluation Dipl.-Ing. G. Tomasev			
Highest normal load (90°), the element must bear against (wind force and static load)		Acc. test report S2.2/09-297-3 for 1,96m And test report TM-1/29/07 für 4,96m			
Highest normal load (90°), the element must bear against (dynamic loads due to snow removal)		Acc. test report S2.2/09-297-4			
Risk of falling structures		Category 3			
Riprap resistance		achieved DIN EN 1794-1:03, enclosure C			

Description of noise protection wall

- Upper- and under chord is out of extruded Aluminium profiles
- Side-sheets with 2 aluminium pleats, unpunched
- Side-cap is out of extruded Aluminium profiles
- Inside 40 mm rock wool, density 120 kg/m³
- Single parts are mounted with rivets



Dipl.-Betr.-Oec (B)
Manfred Rosenstatter
CEO



Ing.
Peter Pichkostner
Quality management

Document composition

Criteria	Executive unit	Documents
Noise absorption DL α	LGA QualiTest GmbH	Test report QEMATAS 8461176-AT1a
Sound damping n DLR	LGA QualiTest GmbH + MFPA Leipzig	
Tare weight	MFPA Leipzig	Test report S2.2/09-297-2
Highest vertical load, ...	Dipl.-Ing. G. Tomasev, Salzburg	Static evaluation
Highest normal load (90°), ...(wind force)	MFPA Leipzig	Test report S2.2/09-297-3 for 1,96m length
	Research institute for streets and bridges, Warsaw	Test report TM-1/29/07 for 4,96m length
Highest normal load (90°), ...(dynamic load due to snow removal)	MFPA Leipzig	Test Report S2.2/09-297-4
Risk of falling wall sections	MFPA Leipzig	Test report S2.2/09-297-1

The tests were done acc to the following norms:

- DIN EN 14388; issue 2005-10; noise protection facilities at roads - regulation
- 01N EN 1793-1; issue 1997-11; noise protection facilities at roads – test procedure to determinate the acoustic properties - Part 1: Produce specific description of sound absorption
- DIN EN 1793-2; issue 1997-11; noise protection facilities at roads – test procedure to determinate the acoustic properties - Part 2: Produce specific description of airborne sound absorption
- DIN EN 1794-1; issue 2003-07; noise protection facilities at roads – Not acoustic properties - Part 1: Mechanical properties and requirements regarding stability
- DIN EN 1794-2; issue 2003-07; noise protection facilities at roads - Not acoustic properties - Part 2: General safety and environmental requirements

Dipl.-Betriebs-Öec (BI)
Manfred Rosenstatter
CEO

Ing.
Peter Pichkostner
quality management

ALU LSW ELC – one-side absorbent

ALUMERO SYSTEMATIC SOLUTIONS GMBH
Austria-5164 Seeham, Sonnenweg 1-2

UID-Nummer: ATU 35038204
Firmenbuchnummer: FN 36681 v
Firmenbuchgericht: Landesgericht Salzburg